

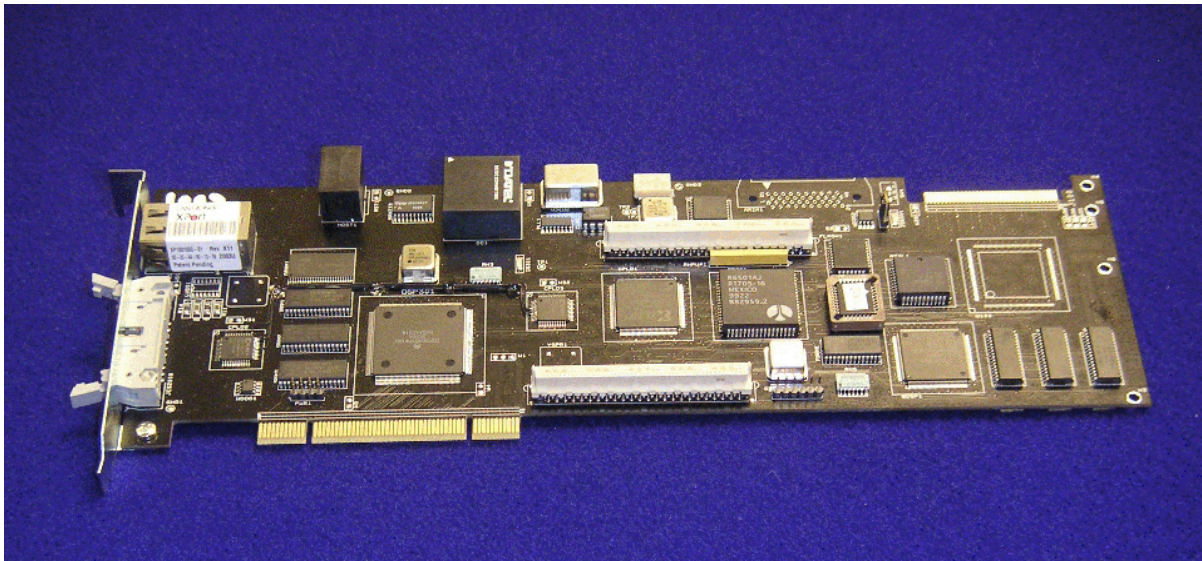

Leaders in VOIP Products and Solutions

IP256.H100 VOIP Board



IP256.H100 Board Specifications:

- | | |
|---------------------------|---|
| Processors: | - (2) Motorola 563xx DSP @ 100Mhz/ea, Embedded micro for TDM timeslot local switching control |
| Interfaces: | - PCI 2.1 / 2.2 (per Motorola), 33Mhz, 3.3V or 5V
- CTBUS / H.100 connector, 4096 channel access
- 256, bi-directional, VOIP streams via system NIC
- 2 – Expansion slots for DSP modules |
| Included Software: | - Open API program for complete client / server command control of IP and TDM ports
- Seamless Intel / Dialogic integration from Global Call
- Open Source device driver and UCL RTP stack
- Any-port to any-port switching, DTMF / tone generation, RTP payload generation and detection (per RFC 2833)
- DTMF detection (w/ optional DSP module)
- PCI Bus Mastering DSP reduces system load
- RTP/IP source code with royalty free rtp stack
- 512 virtual IVR ports, play / record files on IP and TDM channels |
| Warranty: | - One year limited hardware warranty |



Leaders in VOIP Products and Solutions

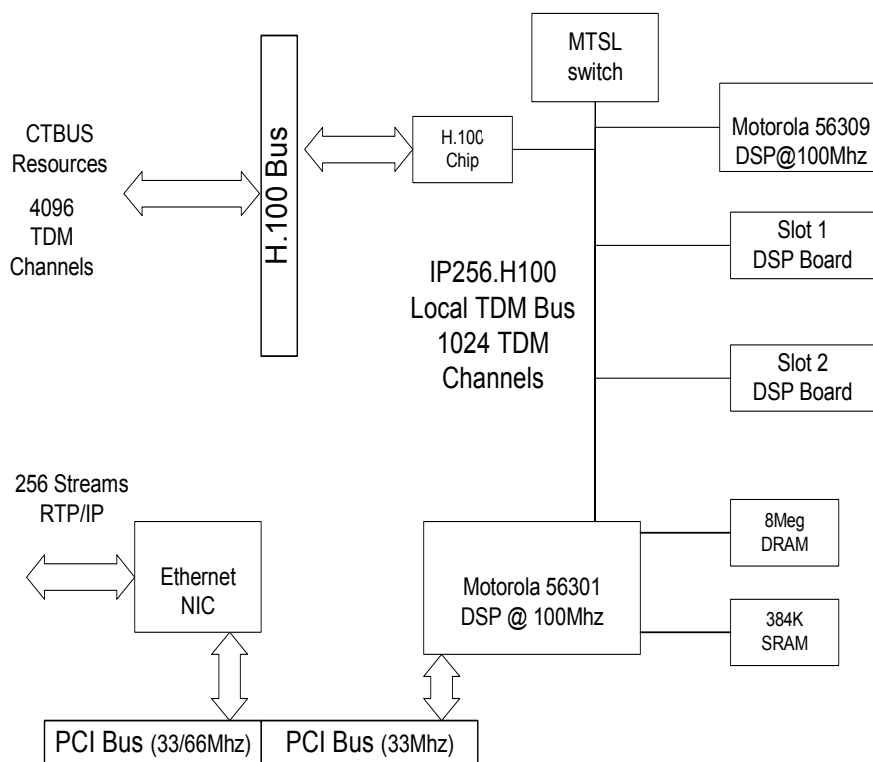

Using the IP256.H100 Board to add VOIP to an Intel / Dialogic Telephony Server

IP256.H100 Features:

- Add 256 bi-directional VOIP channels to existing H100 based Intel / Dialogic Telephony servers
- Open Standards based embedded hardware; Motorola* DSP technology
- PCI 2.2 (Motorola), 32bit, 33Mhz PCI Bus interface @ 3.3V or 5V
- Seamless application control from Dialogic* Global Call
- CTBUS / H.100 connector, provides full access to the 4096 CTBUS channels
- Open Source software provides for full control over RTP/IP data streams
- Support for multiple boards within a single chassis
- High board value, **without** hidden or additional licensing fees